

SPEEDWAY

SPM-562M Case Sealer

Mini type for small boxes

Side Belt Drive

Features:

The SPM-562M uses a new taping head incorporating a V shaped plate (patented) designed to keep the tape straight and in position for consistent sealing of every carton. This design is superior to previous blower devices. Driven by two side drive belts, each belt has a separate drive mechanism using a special bearing bracket. This provides higher precision, lower noise and lengthens belt life. Tape overlap length can be adjusted from 55mm-65mm.

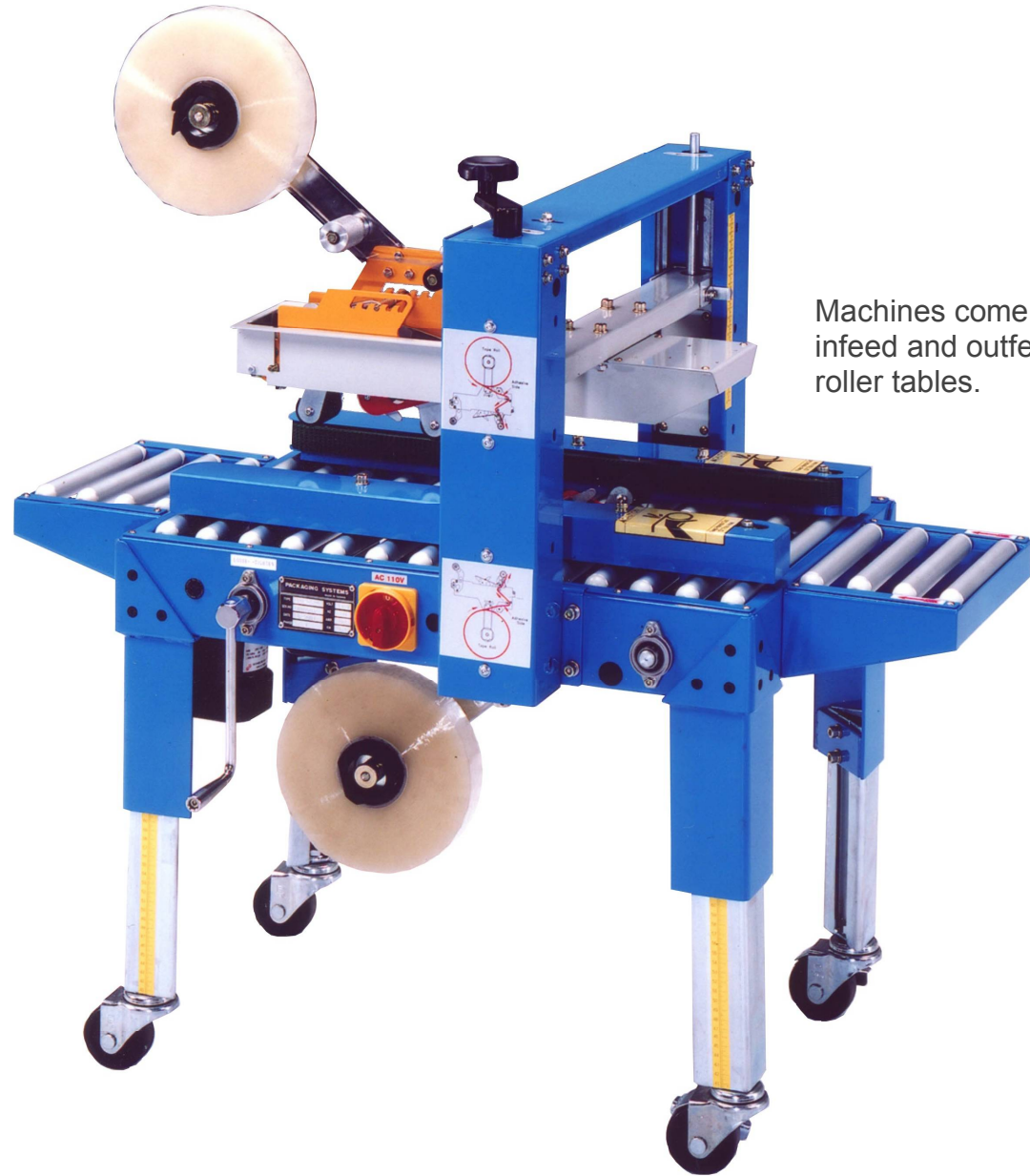

Machines come standard with infeed and outfeed extension roller tables.

Speedway Packaging Machinery Inc.
www.spmi.ca

Manufactured in Taiwan

SPM-562M Case Sealer

Specifications

Voltage	110 V 1 PH 60 HZ
Power	10 amps
	Two motors, 370W
Sealing Speed	20 m/min (66') / min.
Cartons/Hr	1200 cartons per hour
Tape Width	1.5"
Machine Weight	85 kg / 187 lbs
Shipping Weight	135 kg / 297 lbs

Dimensions

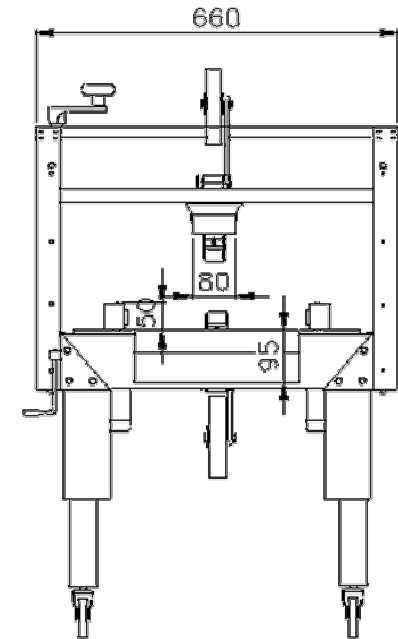
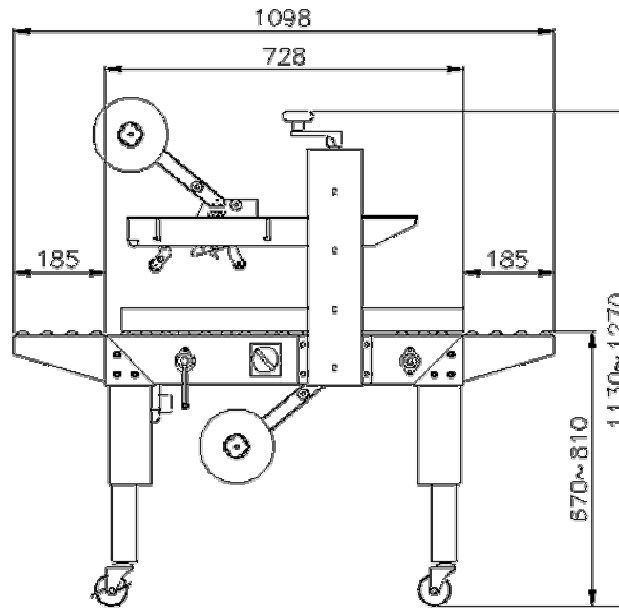
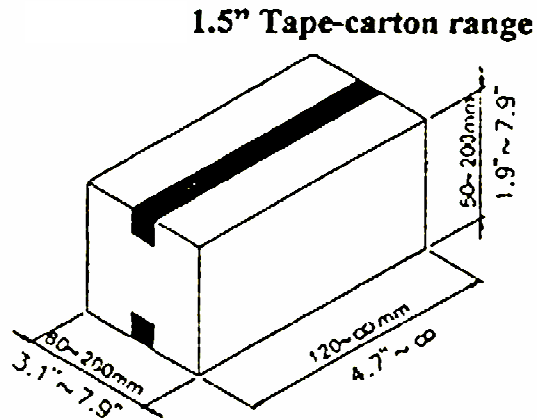

Distributed by:

SPEEDWAY PACKAGING MACHINERY INC.

P.O. Box 520

10 Gormley Industrial Ave., Unit 1

Gormley, Ontario L0H 1G0

905-888-5344

Specifications are subject to change without notice-

NOTE: Not suitable to use this machine if the carton's height exceeds the length.